

**ISOLATOR SUBMITTAL  
 RESTRAINED SPRING, 2" DEFLECTION**

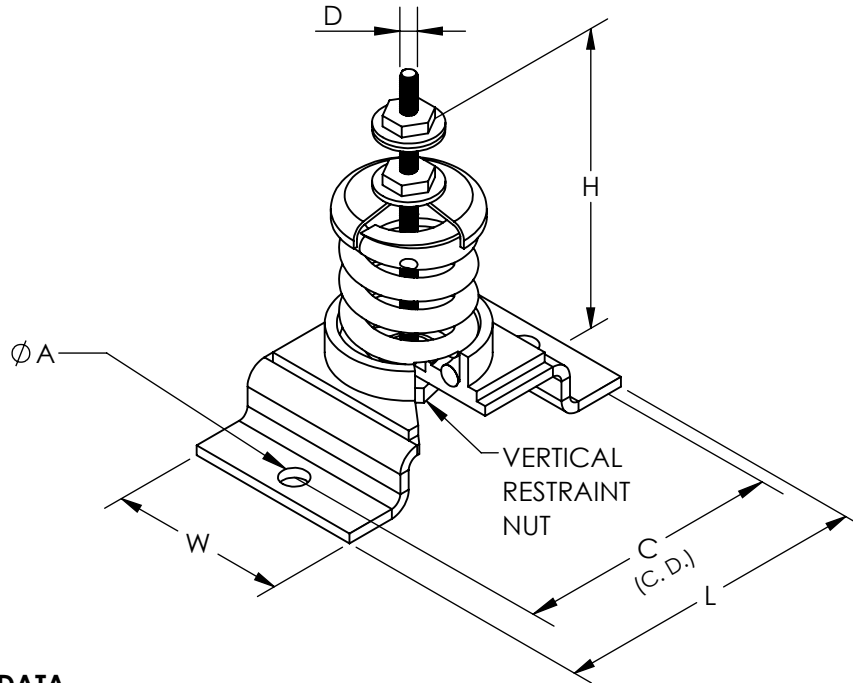

**DIMENSIONAL DATA**

SIZE	L	W	C	A	H	D
2-100/1975	8.00	4.50	6.50	0.69	11.00	0.63

MODEL		SPRING COIL					
		COLOR		FREE HT.	O.D.	RATED (LBS)	
TYPE	SIZE	OUTER	INNER			LOAD	DEFL.
FRS	2-100	GRAY		6.09	3.50	100	2.00
FRS	2-135	BEIGE		6.09	3.50	135	2.00
FRS	2-185	BROWN		6.09	3.50	185	2.00
FRS	2-225	GRAY	BROWN	6.09	3.50	225	2.00
FRS	2-250	BLUE		6.09	3.50	250	2.00
FRS	2-375	BLUE	BROWN	6.09	3.50	375	2.00
FRS	2-500	GREEN		6.09	3.50	500	2.00
FRS	2-625	GREEN	BROWN	6.09	3.50	625	2.00
FRS	2-750	BLACK		6.09	3.50	750	2.00
FRS	2-875	BLACK	BROWN	6.09	3.50	875	2.00
FRS	2-995	ORANGE		6.09	3.50	995	2.00
FRS	2-1120	ORANGE	BROWN	6.09	3.50	1120	2.00
FRS	2-1400	ORANGE	GREEN	6.09	3.50	1400	2.01
FRS	2-1600	RED		6.09	3.50	1600	2.00
FRS	2-1975	RED	GREEN	6.09	3.50	1975	1.98

**NOTES:**

1. VERTICALLY AND LATERALLY RESTRAINED SPRING ISOLATOR.
2. REPLACEABLE NEOPRENE SNUBBER
3. MINIMUM OVERLOAD OF 50%
4. POWDER COATED SPRING ELEMENT, BRACKET IS HOT DIPPED GALVANIZED.
5. FOR ADEQUATE ANCHOR SIZING, TORQUE, AND BASEPLATE REQUIREMENTS, VISIT [kineticsnoise.com/frs/restrained-spring-isolator](http://kineticsnoise.com/frs/restrained-spring-isolator)

ALL DIMENSIONS ARE IN INCHES